



EARTH SHIELD®



CRD C572-74 Certified PVC Waterstops for Concrete



Waterstops play a critical role in the integrity of concrete structures. They provide a fluid-tight diaphragm when embedded in, and running through concrete joints. Earth Shield® Polyvinyl Chloride Waterstop (PVC) is the perfect solution for most water and wastewater applications. Earth Shield® PVC Waterstop is manufactured from prime virgin resin and is the trusted choice for environmental engineered concrete structures.

J P Specialties, Inc. is the leading manufacturer of chemical resistant waterstop and related concrete accessories. We invented the technology used to mechanically weld thermoplastic waterstops.

J P Specialties, Inc.

Phone: 800-821-3859; 951-763-7077

Fax: 951-386-0160

www.jp-specialties.com



Earth Shield® Polyvinyl Chloride (PVC) Waterstop Basic Use

Earth Shield® Polyvinyl Chloride (PVC) Waterstop is used as a fluid-tight diaphragm, embedded in concrete, across and along the joint, for environmental engineered concrete structures. Earth Shield® Flexible PVC Waterstops are resistant to a wide range of water and wastewater treatment chemicals and are certified to meet or exceed the performance requirements of CRD C572-74.

Earth Shield® Advantages

- Outstanding fluid resistance to a wide range of aqueous-based water and waste water treatment chemicals
- Meets ACI 350 “Code Requirements for Environmental Engineering Concrete Structures”
- CRD C572-74 compliant

Installation

Install Earth Shield® Flexible PVC Waterstop in all concrete joints. Waterstop should be centered in, and run the extent of the joint. All changes of directions should be prefabricated, leaving only butt-welding for the field. If installing in an expansion joint, keep center bulb unembedded to allow it to accommodate movement as designed. Use optional factory installed brass eyelets (or #3 hog rings) and tie wire to secure waterstop to reinforcing steel to avoid displacement during the concrete pour. Splice straight lengths of waterstop and Shop Made Fittings to straight lengths, with an ST-10® In-Line Waterstop Splicer with the iron temperature set to 350°F to 380°F. More detailed installation instructions are in our Standard 3-part Specifications.

Standard 3-part Specifications are available at our website in Microsoft® Word and Adobe®

PH SCALE

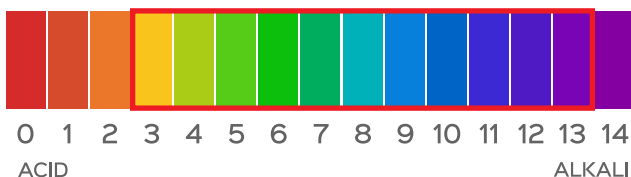

PDF format. Call our Technical Sales Staff for additional help with your specification.

Flexible PVC Waterstop

Waterstop indicated in drawings and specifications for contraction (control), expansion and construction joints shall be Earth Shield® Polyvinyl Chloride (PVC) Waterstop Part No. ##### [Designer insert appropriate part number here] as manufactured by J P Specialties, Inc.; Murrieta, CA 92562; Phone 951-763-7077

1. Flexible Polyvinyl Chloride (PVC) Waterstop shall be manufactured with prime virgin resin.
2. Flexible Polyvinyl Chloride (PVC) Waterstop shall be independently certified for use in potable water per NSF/ANSI Standard 61. Third-party certified documentation to be provided by the manufacturer.
3. Flexible Polyvinyl Chloride (PVC) Waterstop shall be California Prop 65 compliant and contain no hazardous phthalates.
4. No equals or substitutions allowed.

Property	Test Method	Required Results
Specific Gravity	ASTM D792	1.38 to 1.40
Shore A Hardness (15 sec.)	ASTM D2240	77±3 at 25°C (77°F)
Tensile Strength	ASTM D638	2,100 psi
Ultimate Elongation	ASTM D638	400%
Stiffness in Flexure	ASTM D747	700 psi
Tear Resistance	ASTM D624	320 lbs./inch
Brittle Point	ASTM D746	-37°C (-35°F)
Accelerated Extraction Tensile Strength	Corps of Engineers	2,005 psi
Accelerated Extraction Elongation	Corps of Engineers	390%
Effect of Alkali Weight Change	CRD C572-74	+0.11%
Effect of Alkali Hardness Change	CRD C572-74	-0.6 points
Drinking Water Safe	NSF/ANSI 61 	Waterstop certified by NSF for use in potable water

Waterstop Accessories

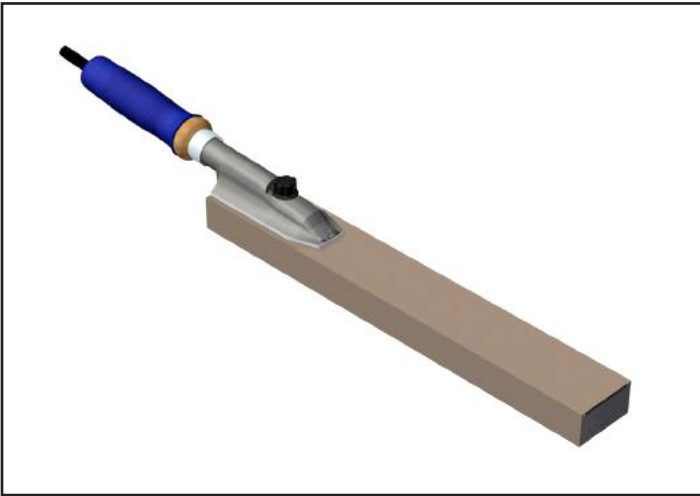

Waterstop Splicing Irons

JPS Standard Irons are specifically designed for welding waterstops and other thermoplastic extruded profiles (expansion joints, seals, etc.). The temperature control can be adjusted from 250°F to 500°F to accommodate various ambient conditions and different polymers. All JPS Standard Irons are constructed with the highest quality components.

- *Peel and Stick Teflon® Cover included*
- *Heavy-duty vinyl grip and wood handle*
- *8-foot, CSA & UL certified, outdoor use power cable*
- *Adjustable temperature with “Off” position*

ST-10 Waterstop Splicing Table

The ST-10® was designed and patented by J P Specialties as the perfect solution for producing high-tensile strength, leakproof welds on thermoplastic waterstops such as PVC, HDPE, LDPE, TPER, and TPV. New quality assurance standards in today's waterstop specifications mandate tensile testing across field welded joints, usually requiring tensile strength 80% or better of the parent material. Waterstops welded with the ST-10® assure the Contractor that their workmanship will yield results conducive to these rigorous requirements. The ST-10® is also an extreme labor saver, taking a two man job — welding waterstop — and taking it down to just one man.

- *Easy to use*
- *Aligns the waterstop*
- *Portable, lightweight*
- *Weather resistant*
- *Minimizes fumes (maximizes safety)*
- *High tensile welds*
- *Welds under pressure, eliminating air bubbles*

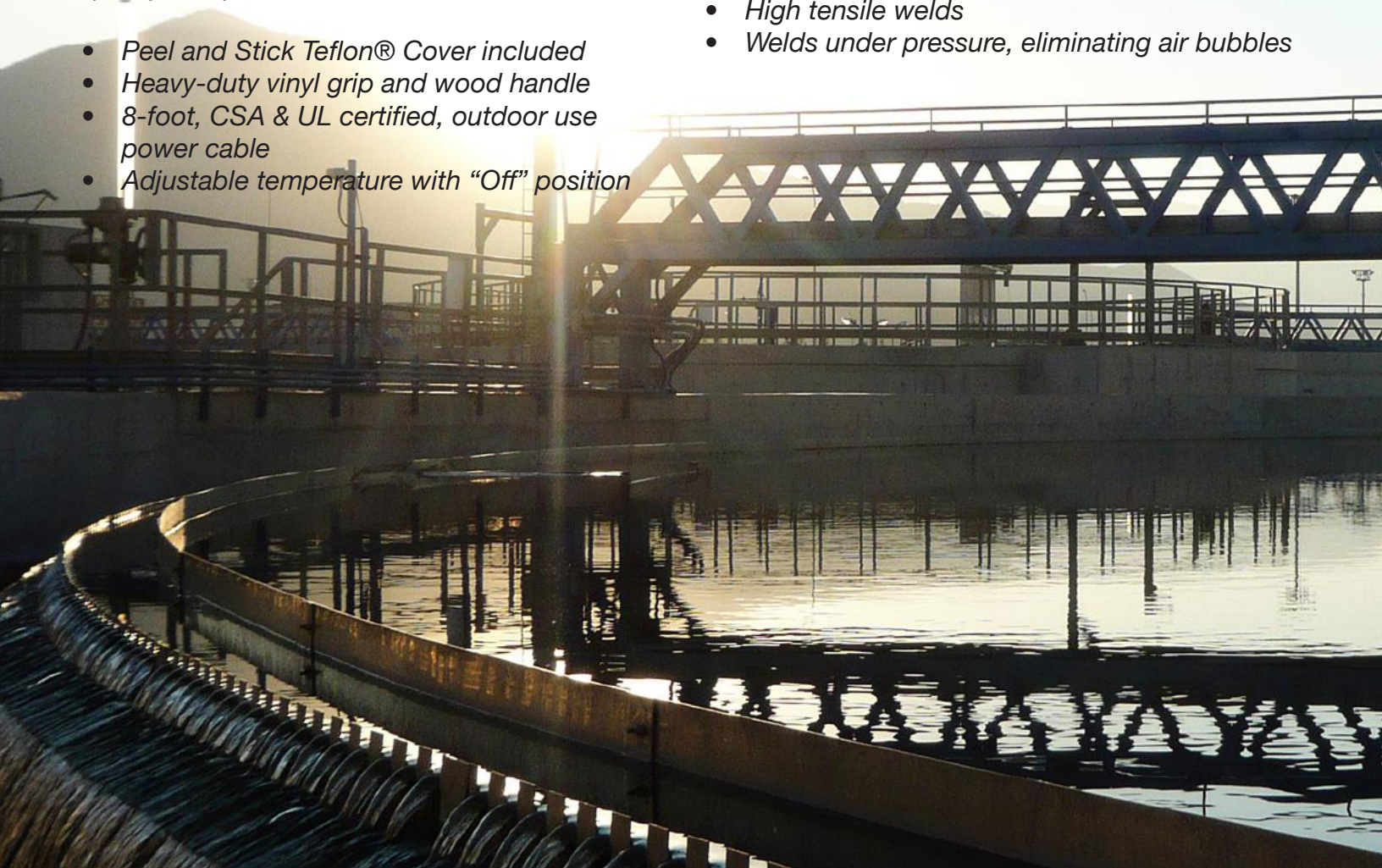

Ribbed Centerbulb

for Moving and Non-Moving Joints

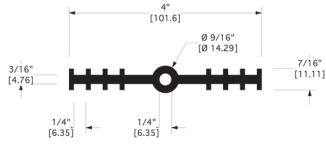

PVC436 (with eyelets: EYPVC436)
4\"/>

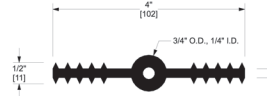

PVC438 (with eyelets: EYPVC438)
4\"/>

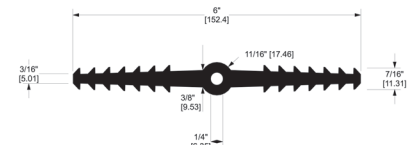

PVC605 (with eyelets: EYPVC605)
6\"/>

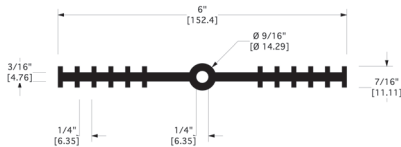

PVC636 (with eyelets: EYPVC636)
6\"/>

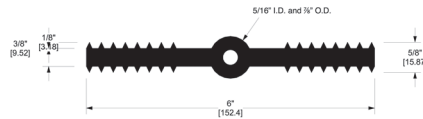

PVC638 (with eyelets: EYPVC638)
6\"/>

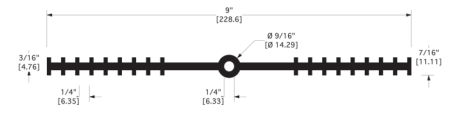

PVC936 (with eyelets: EYPVC936)
9\"/>

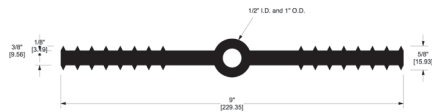

PVC938 (with eyelets: EYPVC938)
9\"/>

Flat Strip

Resists High Head Pressure

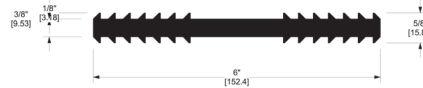

PVC637 (with eyelets: EYPVC637)
6\"/>

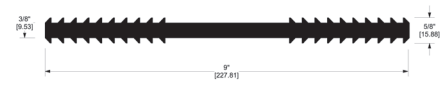

PVC937 (with eyelets: EYPVC937)
9\"/>



Base Seal (aka Rearguard)

for Flatwork and Bund Wall Applications

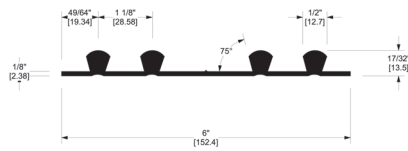

PVC206
6" Base Seal Waterstop
 50 ft Head of H₂O • 50 lft/roll • .89 lbs/lft

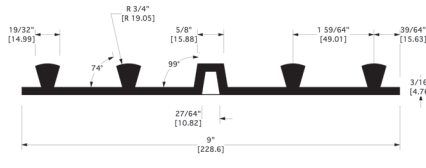

PVC211
9" Base Seal Waterstop
 75 ft Head of H₂O • 50 lft/roll • 1.72 lbs/lft

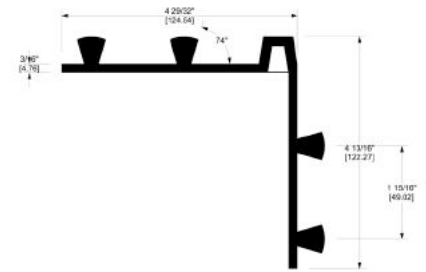

PVC215
6" Corner Seal Waterstop
 50 ft Head of H₂O • 10 lft/length • 1.9 lbs/lft

Retrofit Waterstop Systems

for New to Existing Concrete Joints

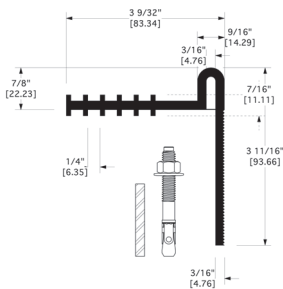

PVC320L (with eyelets: EYPVC320L)
Retrofit Waterstop System
(Includes all batten bars and anchors)
 125 ft Head of H₂O • 10 lft/length • 2 lbs/lft

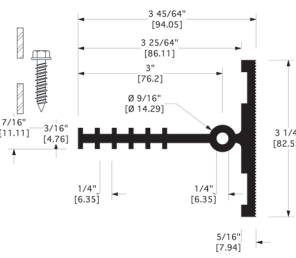

PVC325T (with eyelets: EYPVC325T)
Retrofit Waterstop System
(Includes all batten bars and anchors)
 75 ft Head of H₂O • 10 lft/length • 2 lbs/lft

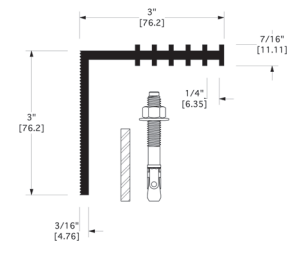

PVC336L (with eyelets: EYPVC336L)
Retrofit Waterstop System
(Includes all batten bars and anchors)
 125 ft Head of H₂O • 10 lft/length • 2 lbs/lft

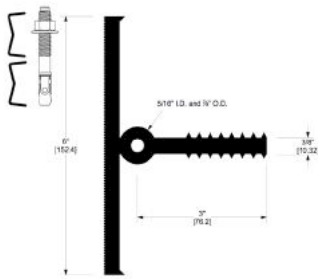

PVC399T (with eyelets: EYPVC399T)
Retrofit Waterstop System
(Includes all batten bars and anchors)
 150 Head of H₂O • 10 lft/length • 4 lbs/lft

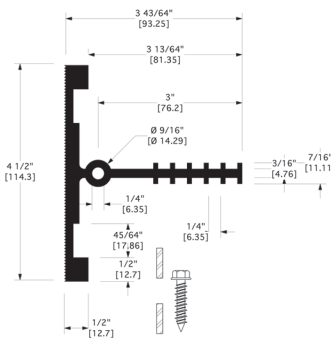

PVC450T (with eyelets: EYPVC450T)
Retrofit Waterstop System
(Includes all batten bars and anchors)
 75 ft Head of H₂O • 10 lft/length • 2 lbs/lft

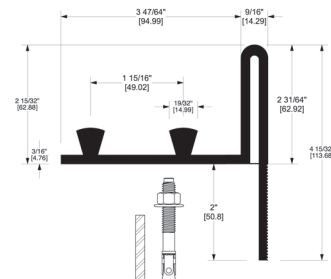

PVC621L
Large Movement Retrofit
(Includes all batten bars and anchors)
 75 ft Head of H₂O • 10 lft/length • 4 lbs/lft

Contact the "Waterstop Experts" at 951-763-7077

Special Shapes for Large Movement Joints

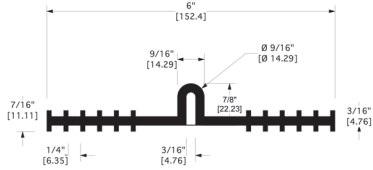

PVC678 (with eyelets: EYPVC678)
6" Tear Web Waterstop
100 ft Head of H₂O • 50 lft/roll • .87 lbs/lft

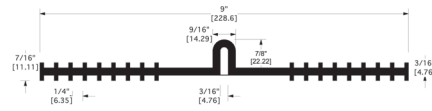

PVC978 (with eyelets: EYPVC978)
9" Tear Web Waterstop
125 ft Head of H₂O • 50 lft/roll • 1.2 lbs/lft



CalTrans California DOT Waterstop

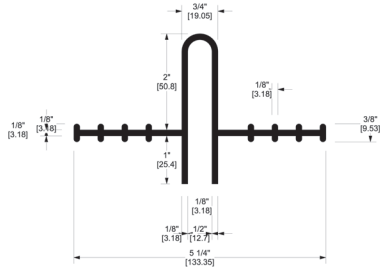

PVC701 (with eyelets: EYPVC701)
5.25" CalTrans W-1 / 2 Waterstop
50 ft Head of H₂O • 50 lft/roll • 1.1 lbs/lft

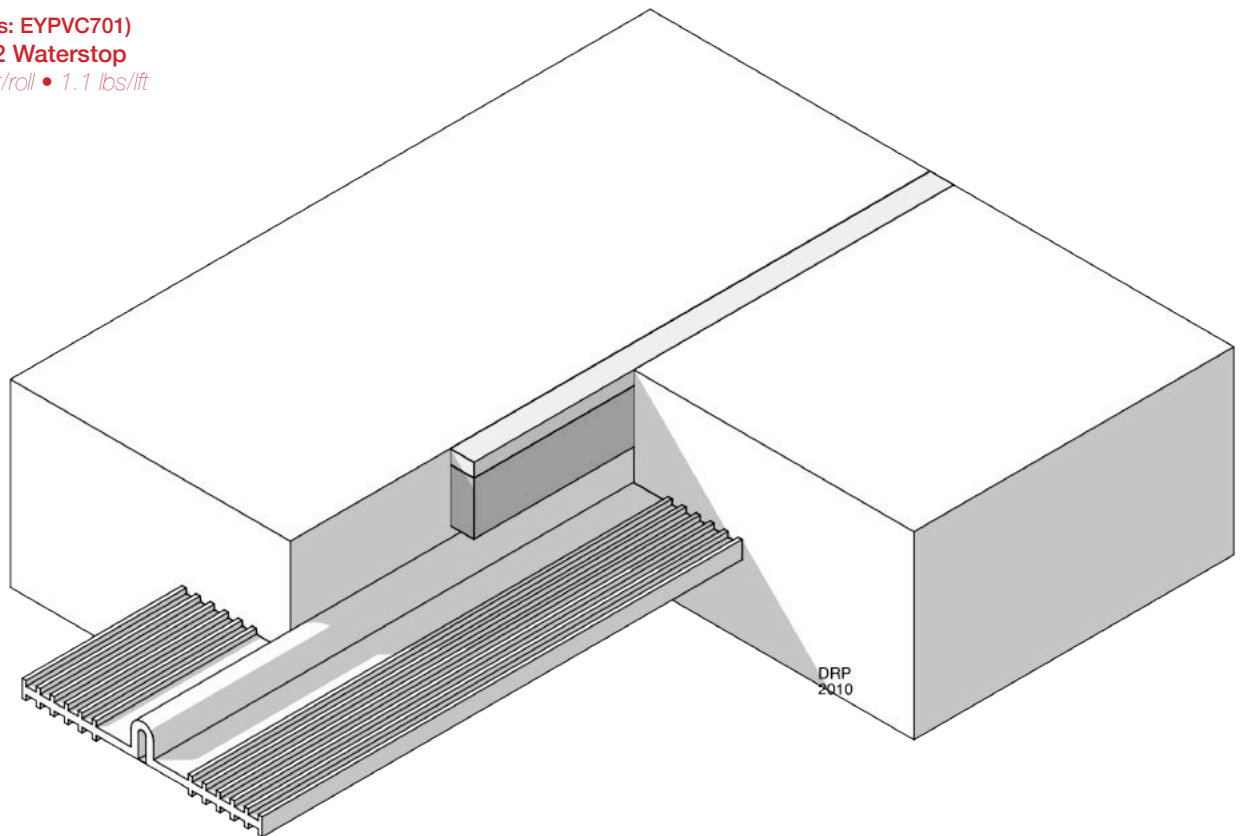

Contact the "Waterstop Experts" at 951-763-7077

Dumbbell

Large Web Thickness for Heavy Concrete

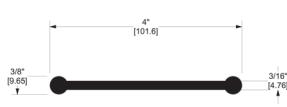

PVC443
4" Dumbbell Waterstop
 65 ft Head of H₂O • 50 lft/roll • .49 lbs/lft

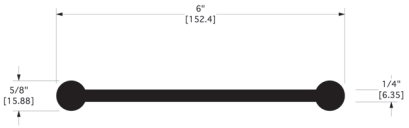

PVC647
6" Dumbbell Waterstop
 100 ft Head of H₂O • 50 lft/roll • .71 lbs/lft



PVC648
6" Dumbbell Waterstop
 125 ft Head of H₂O • 50 lft/roll • 1.59 lbs/lft



PVC948
9" Dumbbell Waterstop
 150 ft Head of H₂O • 50 lft/roll • 2.55 lbs/lft

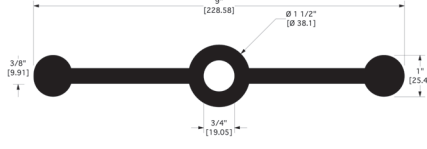

PVC949
9" Dumbbell Centerbulb Waterstop
 150 ft Head of H₂O • 50 lft/roll • 3.1 lbs/lft

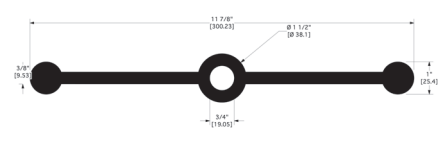

PVC1149
12" Dumbbell Centerbulb Waterstop
 225 ft Head of H₂O • 50 lft/roll • 3.9 lbs/lft

Need Chemical Resistance?

Thermoplastic Vulcanizate Waterstop for Industry



Earth Shield® Thermoplastic Vulcanizate Waterstop (TPV), by J P Specialties, Inc., greatly expands the scope of conventional waterstop by offering unmatched chemical resistance to a broad spectrum of aggressive chemicals, solvents, and hot petroleum oils. Manufactured NSF certified, EPA-compliant waterstop profiles are available for new construction and retrofit, as well as the tools and accessories for proper field installation.

Waterstop Shop Made Fittings

Ensure A Quality, Leak-Proof Project

Shop Made Fittings are recognized and specified worldwide by major engineering firms. The U.S. Army Corps of Engineers also specified Shop Made Fittings in the July 1995 revision of CEGS Section 03250. Shop Made Fittings are specified because they work. Edge-welding waterstop severely compromises the integrity of any project. Even the limited movement of concrete during the coefficient of expansion and contraction can be too much for edge welded waterstop. The edge welded waterstop lacks the proper tensile strength and does not maintain the characteristics of the parent material (bulb or rib continuity). Consequently, the waterstop often tears at the most critical junction: the change of direction. Since all waterstops are designed to act as a continuous, fluid-tight diaphragm which fluids (generally water) traverse, the structure that uses edge welded waterstop will naturally leak, as fluids migrate to any tears in the weld and pass through to the other side of the joint.



Structures that use Shop Made Fittings will significantly reduce these waterstop failures. The tensile strength of the weld will be at least 80% of the parent material, maintaining the continuity of the bulbs and ribs across the weld. In other words, the waterstop will perform as intended and last the life of the structure.

J P Specialties has an extensive library of CAD drawings that illustrate the many uses of various Shop Made Fittings and explain waterstop's role in creating a fluid-tight structure.

J P Specialties certified welding crew efficiently manufactures large quantities of top-quality Shop Made Fittings with speed on our exclusive XLT-2000 Waterstop Splicing Tables. Therefore, we can pass the savings on to the end user: the contractor. Besides saving money, the contractor who uses Shop Made Fittings will save time. A standard flat cross has twelve cuts and seven welds. By using Shop Made Fittings, all of the cuts and three of the welds are eliminated. The number of welds is further reduced by using modules.



Retrofit Column and Pipe Fitting

Earth Shield® has solved a long-standing problem for engineered concrete structures with circular protrusions, such as columns, pipes, piers, and pilasters. The problem: how to permanently seal the concrete joint when cast-in-place concrete is formed against an existing circular member. The solution: Earth Shield® Column & Pipe Fitting (part no. PVC320LC1.XX* [*XX is the diameter in inches]) is manufactured with a flexible PVC and stainless steel anchoring hardware. A single laborer on the job site can quickly install the column fitting and its associated hardware. Just apply an epoxy gel bed to the existing surface; place the polymer ring into the epoxy gel bed; heat weld the single opening on the polymer ring using a waterstop splicing iron; and finally, complete the system with the stainless steel closure ring.

The Earth Shield® system functions as an internal dam, centrally located within the cast concrete, to stop water from penetrating the joint. The tear-web design of the PVC320L profile, enable the column fitting to function equally well in expansion (isolation) joints and construction joints.

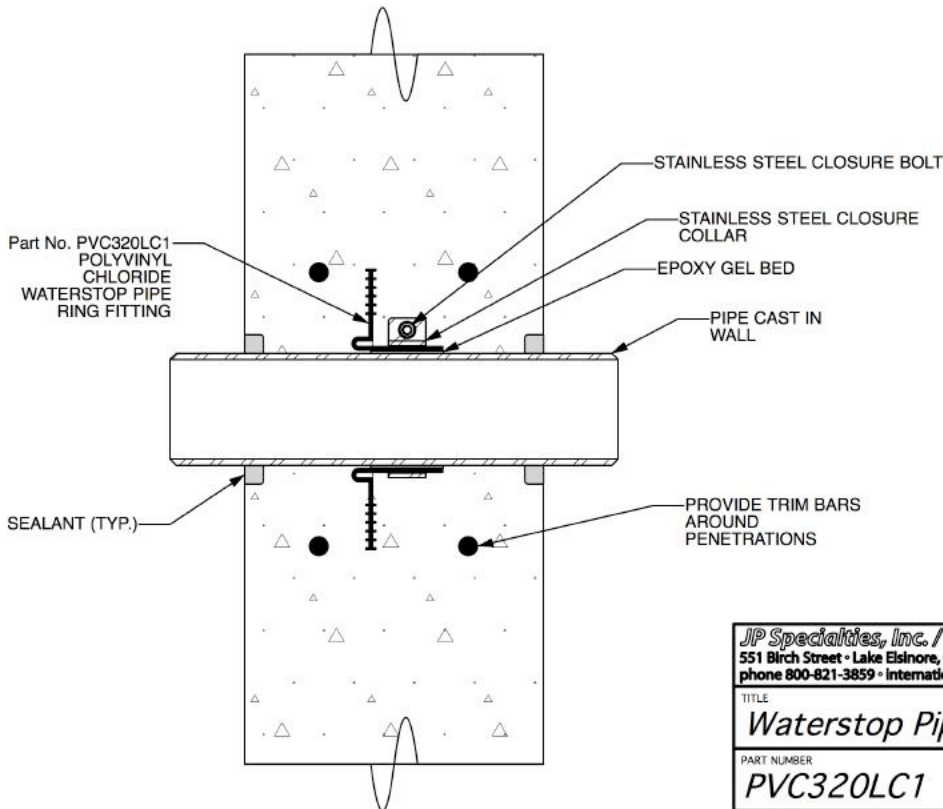
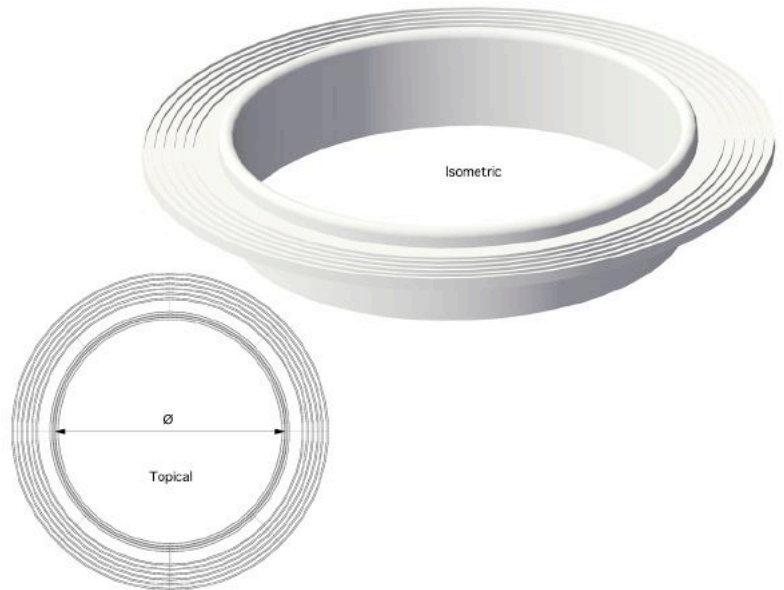

JP Specialties, Inc. / Earth Shield® 551 Birch Street • Lake Elsinore, CA 92530 www.jp-specialties.com phone 800-821-3859 • international 951-674-6869 • fax 951-674-1315		
TITLE Waterstop Pipe Fitting		
PART NUMBER PVC320LC1	DRAWN BY DRP	DATE 05/18
CAD FILE NAME ACI350_2R_Waterstop_Collar	APPROVALS	SIZE A

Contact the "Waterstop Experts" at 951-763-7077

Made in t

CRD C572-74 Waterstops f

Manufactured
with pride by



J P SPECIALTIES, INC.

www

the U.S.A.

J P Specialties, Inc. manufactures a wide range of high-quality waterstop and waterstop accessories for the concrete construction industry. Our Earth Shield® line of flexible PVC waterstop is designed to fluid-proof construction, expansion, and contraction joints of environmental engineered concrete structures. Our waterstop welding equipment is used industry-wide as the standard for quality, high tensile strength waterstop welds. Knowing that a waterstop will only offer a fluid-tight barrier if change of directions are done properly, J P Specialties has been a leader since 1954 in Prefabricated Waterstop Modules and Shop Made Fittings.

Certified PVC for Concrete

JPSPECIALTIES.COM

Availability

National and International Warehouses

Earth Shield® Flexible Polyvinyl Chloride Waterstop is readily available from a variety of sources:

- **Preferred Regional Stocking Partners** — *We are partners with some of the very best Concrete Accessories Distributors in the world. All our preferred partners have large stocking inventories and are factory trained to provide the utmost in on-site assistance.*
- **Distributor Sales** — *Earth Shield® can be special ordered from many distributor sales channels throughout the world.*
- **Factory Direct** — *Earth Shield® may be contacted directly for project quotation and product purchase (call 800-821-3859).*

Services

- *Project and Product Certification* — *We assist the Design Engineer and Project Owner with individual project and product certification. When you specify our waterstop, you can be assured it is the correct product for your application.*
- *On-site waterstop welding certification class* — *\$500.00 flat fee*
- *On-site waterstop installation assistance* — *\$1,000.00 per day*
- *Telephone and Web-based assistance* — *Always FREE*

Distributed by:

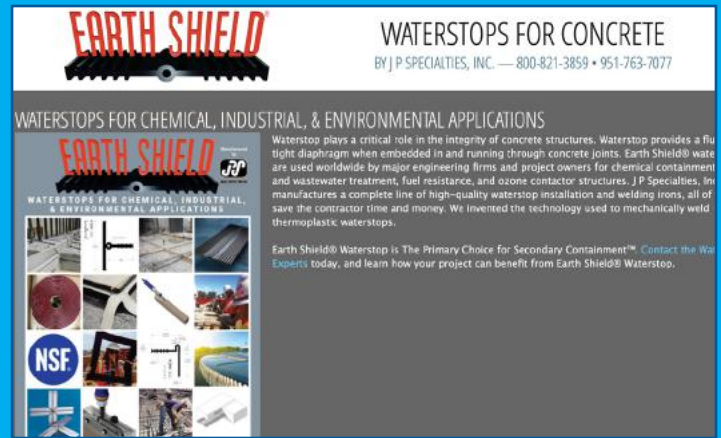

Visit Earth Shield® on the web at
www.jpsspecialties.com



Earth Shield® Waterstop Limited Warranty
J P Specialties, Inc. warrants to the Buyer that this product is new and will be free from defects and will perform as represented in writing subject to the two (2) following conditions: First, the application of the product and the concrete construction practices used in the application are in accordance with J P Specialties, Inc. recommendations; and, Second, the Buyer has selected the proper product for the specific application required.

Any information supplied in good faith by J P Specialties, Inc. with respect to its products is believed to be correct. J P Specialties, Inc. Makes no representation or warranties, expressed or implied, as to the accuracy or completeness of such information.

The exclusive remedies of the Buyer and the limit of the liability of J P Specialties, Inc. from any and all losses or damages resulting from the use of this product shall be either full refund of the purchase price to the Buyer of this product or the replacement of the quantity of product purchased by the Buyer at the discretion of J P Specialties, Inc.

All supplied testing data has been performed by independent testing laboratories.

J P Specialties, Inc.
Phone: 800-821-3859; 951-763-7077
Fax: 951-386-0160
www.jpsspecialties.com



 www.facebook.com/waterstop