

1) Prepare existing concrete by grinding away any irregularities.

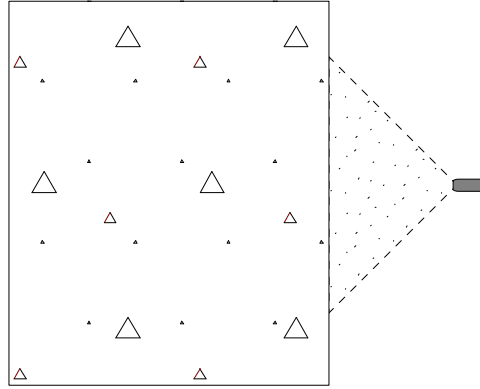

2) Thoroughly clean existing concrete using a wire brush, high pressure waterblast, or sand blast.

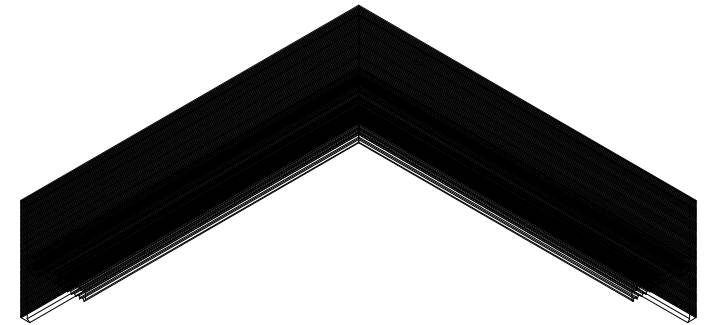

3) Heat weld waterstop profile to appropriate length and directional changes to fit concrete surface.

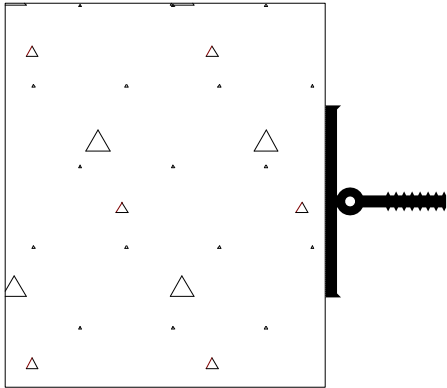

4) Check heat welded waterstop for proper location, orientation and fit.

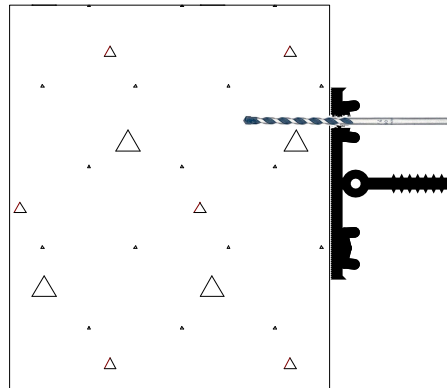

5) Using the prepunched stainless steel batten bar as a template, drill 1/4" holes 2-3/4" deep through waterstop and concrete. Clean out holes. can.

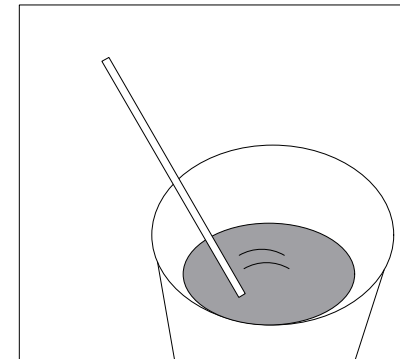

6) Mix appropriate amount of epoxy per mixing instructions on epoxy can.

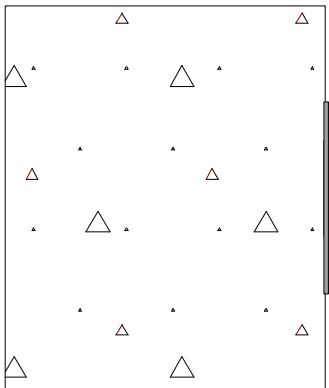

7) Place epoxy strip 1/8" thick by 6" wide on concrete surface.

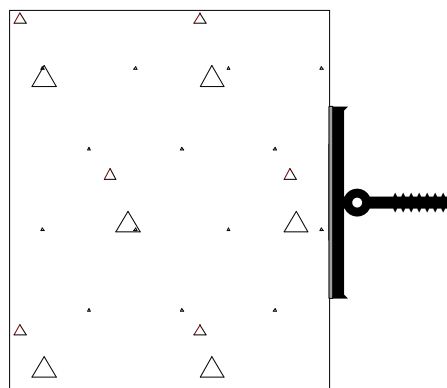

8) Embed waterstop into strip of uncured epoxy.

J P Specialties, Inc. / Earth Shield® Waterstop
 25811 Jefferson Avenue, Murrieta, CA 92562
 951-763-7077 • www.jp-specialties.com

TITLE		
399T Retrofit Install		
PART NUMBER	DRAWN BY	DATE
	DRP	09/18
CAD FILE NAME	APPROVALS	SIZE
399T Retrofit Install		A

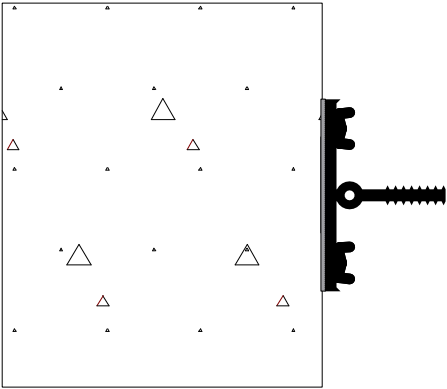

9) Place stainless steel batten bar against flat leg of waterstop.

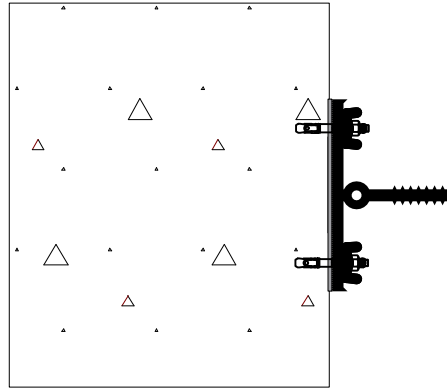

10) Hammer stainless steel wedge anchors into drilled holes, passing anchor through batten bar, waterstop and epoxy gel bed. Repeat for all holes. Tighten anchor bolts.

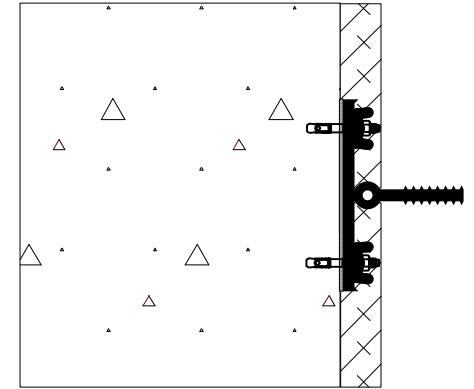

11) If expansion joint install expansion joint filler above and beneath waterstop embedment leg.

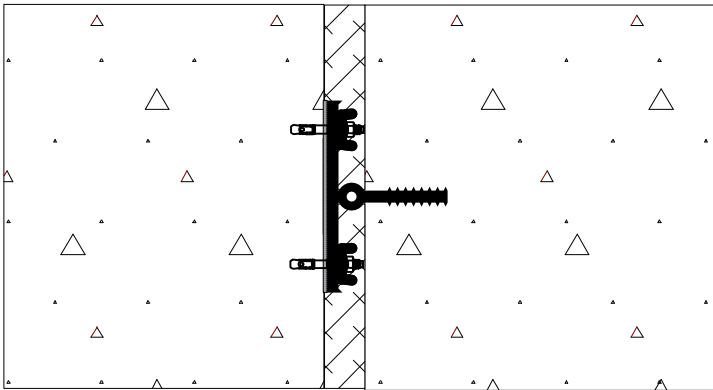

12) Allow installed retrofit waterstop system to cure for 24 hours before placing the second pour of concrete.

For welding, fabrication, placement, execution, and quality assurance please follow all procedures stated in Earth Shield® Master Specification Section 03250.